

CONSLER® FILTRATION PRODUCTS

CONSLER CP SERIES COMPRESSED GAS FILTERS

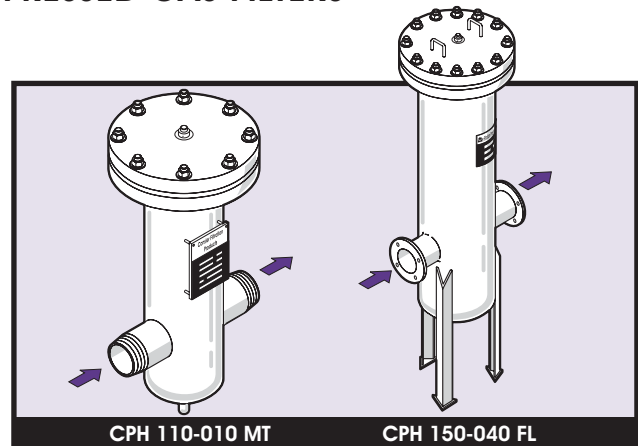
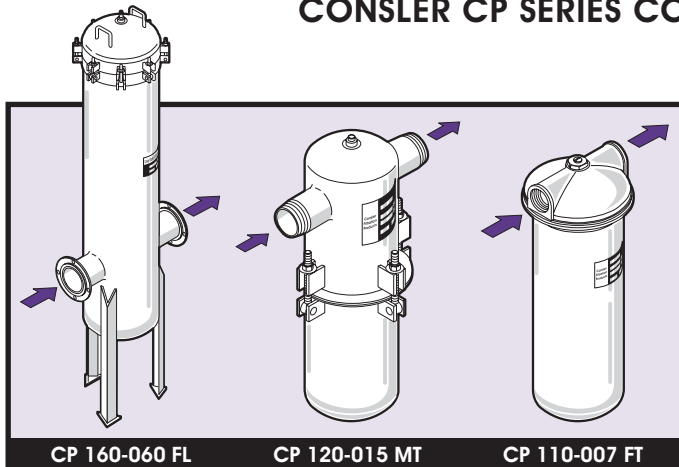

Features

- ASME Code designed and constructed
- Low pressure drop—low energy loss
- High flow rate capability
- Maximum filter area and dirt holding capacity
- Cleanable, reusable filter element
- In line connections
- Modified and custom designs available
- Design Pressures from 180 psi to 740 psi
- Contact Factory for higher pressure applications

Applications:

- Efficient removal of dust, dirt, pipescale, and other solid contaminants from compressed air and gas pipelines.
- Effective filtering of high pressure process gas streams to remove product or byproduct solids.
- Filtering of solid particles ranging from 0.3 to 750 microns.
- Positive protection of pneumatic controls, meters, and other pipeline equipment.
- Low pressure applications where pressure loss is critical.
- Filter efficiencies to 99.97 %.

Element Design & Construction

The CP Series filter offers a replaceable, cleanable element that incorporates a pleated or "radial fin" cartridge design. The element offers maximum filter area in a compact filter assembly, and provides positive gasket sealing to prevent by-pass of unfiltered gasses. Long filter life, low pressure drop, large dirt holding capacity and efficient filtration are assured. Most models employ only one filter element to permit quick and simple cartridge change out.

Standard models, CP 115 and larger, are furnished with a cleanable, sewn-end constructed element which can be reconditioned before replacement is necessary. Following several field cleanings this unique element style can be returned to the factory for recovery and reconditioning.

Element Materials

Standard elements are furnished with a polyester filter medium providing nominal efficiency on 10 micron solid particles. CP

Series elements are also supplied in many alternate materials offering a particle retention range from 0.3 to 750 microns. Optional filter materials available include nylon, fiberglass, cotton, polypropylene, NOMEX*, rayon, wool, DACRON*, TEFLON*, and wire cloth providing an application range from sub-zero temperatures to 1000° F.

Standard elements are furnished with a carbon steel center core and corrosion resistant steel support frame. 304 Stainless Steel and other materials are available.

Housing Design and Construction

Materials of construction include carbon steel, 304 and 316 Stainless Steel as well as other alloys. Housings are designed and constructed in accordance with ASME Code Section VIII, Division I requirements for unfired pressure vessels 5 1/4" diameter and above and are available with "U" Stamp registration and certification. Inlet/outlet connections are furnished in a horizontal in-line configuration. All models can be quickly serviced without breaking pipe connections.

Standard Model Features

- Leg Supports
 - CP 160 and larger
 - CPH 130 and Larger
 - CPHH 130 and larger
- Closure Assembly
 - CP 180 thru 200 – hinged closure assembly
 - CP 210 and larger – swing away cover devices
 - CPH 160 and larger – swing away cover devices
 - CPHH 150 and larger – swing away cover devices
- 1/4" NPT Gauge Connections on Inlet/Outlet Nozzles
 - CP 115 and larger
 - CPH 120 and larger
 - CPHH 120 and larger

* DuPont registered trademark

(Continued on page 5)

CP Series Specifications

Model No.	Conn.		Dimensions-Inches ¹					Housing Gasket Part No.	Element			Approx. Weight Lbs.
	Size	Style	A	B	D	E	F		Part No.	No Req'd.	Total filter Area Sq. Ft.	
CP 110-005 FT	1/2	FPT	3 5/8	7/8	12 3/4	4 5/8	10 3/4	40313	10824K5	1	1.8	7
CP 110-007 FT	3/4	FPT	3 5/8	7/8	12 3/4	4 5/8	10 3/4	40313	10824K5	1	1.8	7
CP 110-010 FT	1	FPT	3 5/8	7/8	12 3/4	4 5/8	10 3/4	40313	10824K5	1	1.8	7
CP 115-015 MT	1 1/2	MPT	5 1/4	3	17	11	10	6003N04	19583K5 ²	1	2.2	20
CP 120-015 MT	1 1/2	MPT	6 1/4	3	19	12	12	6004N04	19584K5 ²	1	3.9	30
CP 130-020 MT	2	MPT	8 1/4	4 1/2	20	18	12	6005N04	19585K5 ²	1	6.6	45
CP 140-030 MT	3	MPT	8 1/4	4 1/2	27 1/4	18	17	6005N04	19586K5 ²	1	9.8	50
CP 150-040 MT	4	MPT	10 1/4	5 1/2	35 1/4	20	21	6006N04	19587K5 ²	1	15.4	80
CP 150-040 FL	4	FLG	10 1/4	5 1/2	35 1/4	20	21	6006N04	19587K5 ²	1	15.4	90
CP 160-060 FL	6	FLG	12 3/4	29 1/2	59	22 3/4	26	6007N03	19794K5 ²	2	33.5	330
CP 180-080 FL	8	FLG	16	31	77	26	26	6008N03	19571K5 ²	2	62.6	434
CP 190-100 FL	10	FLG	20	33 1/2	84	32	26	6009N03	19758K5	2	95.0	768
CP 200-120 FL	12	FLG	24	35 1/2	90	36	26	6010N03	19572K5	2	136.0	1025
CP 210-140 FL	14	FLG	28	37 1/2	93	44	26	6011N03	19759K5	2	223.0	1235
CP 220-160 FL	16	FLG	30	39	110	50	26	6012N03	19560K5	3	321.0	1610
CP 230-200 FL	20	FLG	36	43	132	54	26	6013N03	19761K5	3	442.0	2452
CP 240-240 FL	24	FLG	42	46	142	62	26	6017N03	19592K5	3	526.0	3344

1. All dimensions are approximate. 2. See optional elements, pg. 8.

- Standard filters are supplied with a 10 micron polyester filter medium (200° F) and a NEOPRENE* closure gasket (300° F). Contact your Consler representative for other available materials.
- Models CP 110 have a maximum design of 150 psig at 100° F.
- Models CP 115 thru 240 have 1/4" NPT plugged gauge connections.
- Models CP 115 thru 150 have 1/2" drain and vent connections.
- Models CP 160 thru 200 have 1" drain and vent connections.
- Model CP 160 has two (2) handles for closure removal. Models CP 180 thru 200 have a hinged closure with one (1) handle. Models CP 210 thru 240 have a swing away closure device and one (1) handle.
- Models CP 160 thru 200 have three (3) leg supports with a length of 18" from bottom of vessel to grade. CP 210 thru 240 have special vessel supports that are supplied to suit the application.
- Flanged end models have 150# ANSI, R.F.S.O. Flanges.

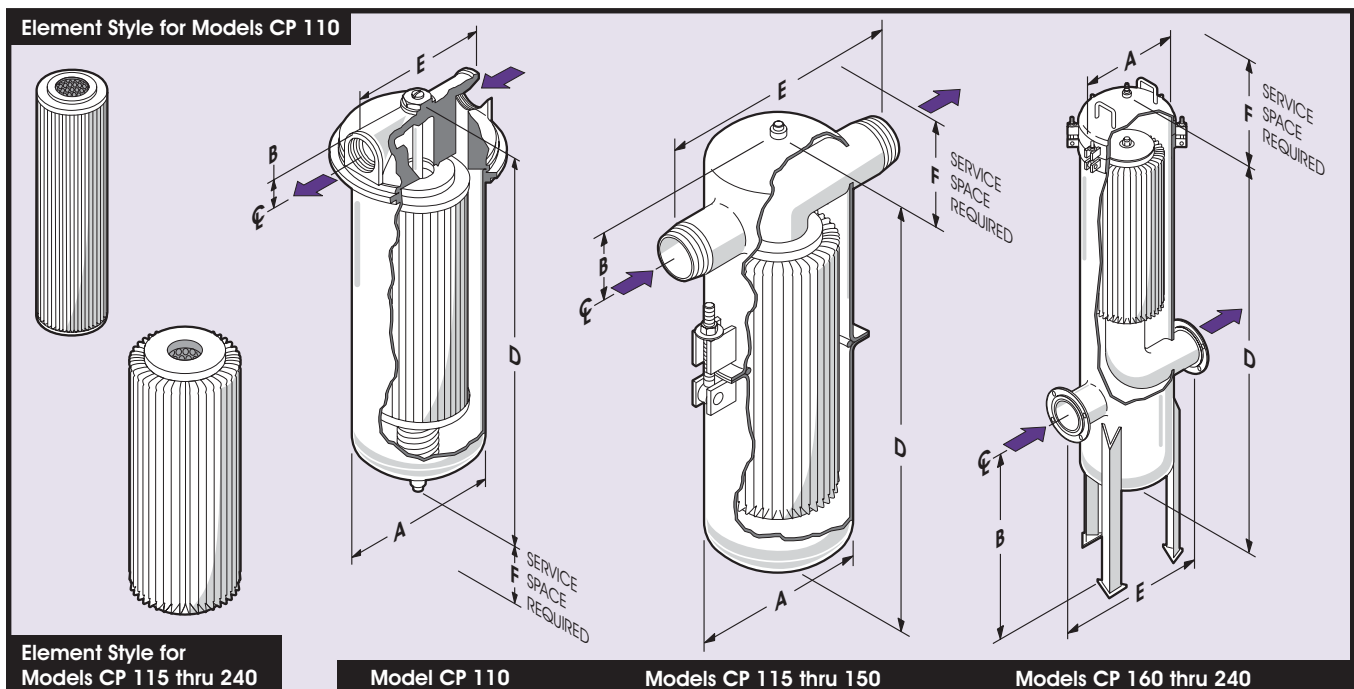

CP Flow Rate Capability Charts¹

Capacity (SCFM) vs. Differential Pressure (psi)
At 60° F—Specific Gravity 1.0 (Air)²

Inlet Press.	CP Model	Inches WC Δp				psi Δp		
		0.5"	1"	5"	10"	0.5	1	2
50 psig	110-005 FT	7.6	10	24	34	40	56	80
	110-007 FT	13	18	40	58	68	96	137
	110-010 FT	22	32	74	100	118	168	240
	115-015 MT	53	75	168	238	280	400	560
	120-015 MT	53	75	168	238	280	400	560
	130-020 MT	88	120	278	386	460	650	920
	140-030 MT	200	280	630	890	1050	1450	2000
	150-040 MT	350	500	1120	1580	1875	2580	3420
	160-060 FL	920	1300	2920	4150	4900	6600	8700
	180-180 FL	1500	2100	4800	6800	8000	10700	14000
	190-100 FL	2280	3200	7100	10100	11950	16900	22000
	200-120 FL	3600	5000	11350	16000	19000	26500	37800
	210-140 FL	3800	5200	11700	16800	19800	28000	40000
	220-160 FL	5700	8000	18000	25500	30000	43000	61500
	230-200 FL	9600	13700	30000	43500	51000	73000	104000
	240-240 FL	13700	19000	43000	60000	72000	102000	145000
100 psig	110-005 FT	10	14	32	46	54	76	108
	110-007 FT	17	24	54	76	90	128	180
	110-010 FT	30	42	93	132	156	220	312
	115-015 MT	70	100	224	320	370	530	740
	120-015 MT	70	100	224	320	370	530	740
	130-020 MT	114	160	358	510	600	850	1200
	140-030 MT	268	380	840	1190	1400	2000	3100
	150-040 MT	468	660	1490	2080	2480	3500	5200
	160-060 FL	1140	1600	3600	5120	6000	8500	12000
	180-180 FL	2000	2800	6300	9000	10550	15000	21600
	190-100 FL	3000	4300	9600	13900	16000	22900	32000
	200-120 FL	4780	6600	15000	21000	25000	35750	50500
	210-140 FL	5000	7000	15800	22000	26000	37000	52200
	220-160 FL	7400	10400	23600	33000	39000	55250	78000
	230-200 FL	12900	18000	40000	57500	68000	95000	135000
	240-240 FL	18000	26000	57000	80000	95000	136000	195000
150 psig	110-005 FT	12	17	38	54	64	90	128
	110-007 FT	21	28	66	92	110	155	220
	110-010 FT	35	50	110	160	186	268	370
	115-015 MT	84	120	265	374	440	630	890
	120-015 MT	84	120	265	374	440	630	890
	130-020 MT	138	195	440	615	730	1030	1440
	140-030 MT	318	440	1000	1420	1680	2380	3370
	150-040 MT	562	800	1800	2500	3000	4200	5950
	160-060 FL	1390	1950	4400	6200	7400	10350	13890
	180-180 FL	2430	3400	7600	10700	12800	18000	25500
	190-100 FL	3590	5000	11400	15900	19000	27000	38000
	200-120 FL	5700	8000	18000	25500	30000	42400	58500
	210-140 FL	5980	8200	18900	27000	31800	44900	62000
	220-160 FL	9000	12800	29000	40000	48000	68000	95000
	230-200 FL	15500	22000	49000	69500	81000	116000	162000
	240-240 FL	22000	31000	69000	98000	11500	164000	234000

1. Values are based on actual test results or empirical calculations.

2. To determine proper filter sizing for gases other than air, multiply pressure drop by the correction factor for the appropriate gas from chart on back cover. For temperatures greater than 60° F, multiply pressure drop by the absolute temperature factor: $\frac{460 + (°F)}{520}$

CPH Specifications

Model No.	Connection		Dimensions - Inches ¹					Housing Gasket Part No.	Element			Approx. Weight Lbs.
	Size	Style	A	B	D	E	F		Part No.	No Req'd.	Total filter Area Sq. Ft.	
CPH 110-005 MT	1/2	MPT	4 1/2	4	15 3/4	10	10	6015PSO	10824K5	1	1.8	55
CPH 110-007 MT	3/4	MPT	4 1/2	4	15 3/4	10	10	6015PSO	10824K5	1	1.8	55
CPH 110-010 MT	1	MPT	4 1/2	4	15 3/4	10	10	6015PSO	10824K5	1	1.8	55
CPH 120-015 MT	1 1/2	MPT	6 5/8	5 3/4	23 1/4	13 1/2	12	6016PSO	19583K5 ²	1	3.9	95
CPH 130-020 FL	2	FLG	8 5/8	7 1/4	23 1/4	18	12	6017PSO	19585K5 ²	1	6.3	180
CPH 140-030 FL	3	FLG	8 5/8	7 3/4	30 1/2	18	17	6017PSO	19586K5 ²	1	7.2	185
CPH 150-040 FL	4	FLG	10 3/4	9 1/4	37 3/4	20	21	6018PSO	19587K5 ²	1	12.7	300
CPH 160-060 FL	6	FLG	12 3/4	11 1/2	47	22 3/4	26	6019PSO	19794K5 ²	2	33.5	450
CPH 180-080 FL	8	FLG	16	13	77	26	26	6020PSO	19571K5 ²	2	62.6	880
CPH 190-100 FL	10	FLG	20	15 1/2	80	32	26	6021PSO	19758K5	2	95.0	1250
CPH 200-120 FL	12	FLG	24	17 1/2	86	36	26	6022PSO	19572K5	2	136.0	1725

1. All dimensions are approximate. 2. See optional elements, pg. 8.

- Standard filters are supplied with 10 micron polyester filter medium (200° F). Contact your Consler representative for other available materials.
- Models CPH 120 thru 200 have 1/4" NPT plugged gauge connections.
- Models CPH 110 thru 150 have 1/2" NPT plugged drain and vent connections.
- Models CPH 160 thru 200 have 1" NPT plugged drain and vent connections.
- Models CPH 130 thru 200 have three (3) leg supports with length of 18" from bottom of vessel to grade.
- Models CPH 130 thru 150 have two (2) handles for closure removal.
- Models CPH 160 thru 200 have a swing away davit device and one (1) handle.
- Flanged models have 150# ANSI, R.F. flanges.
- CPH Series standard gasket material is a CG style spiral wound, with 304 Stainless Steel compression ring and graphite filler.

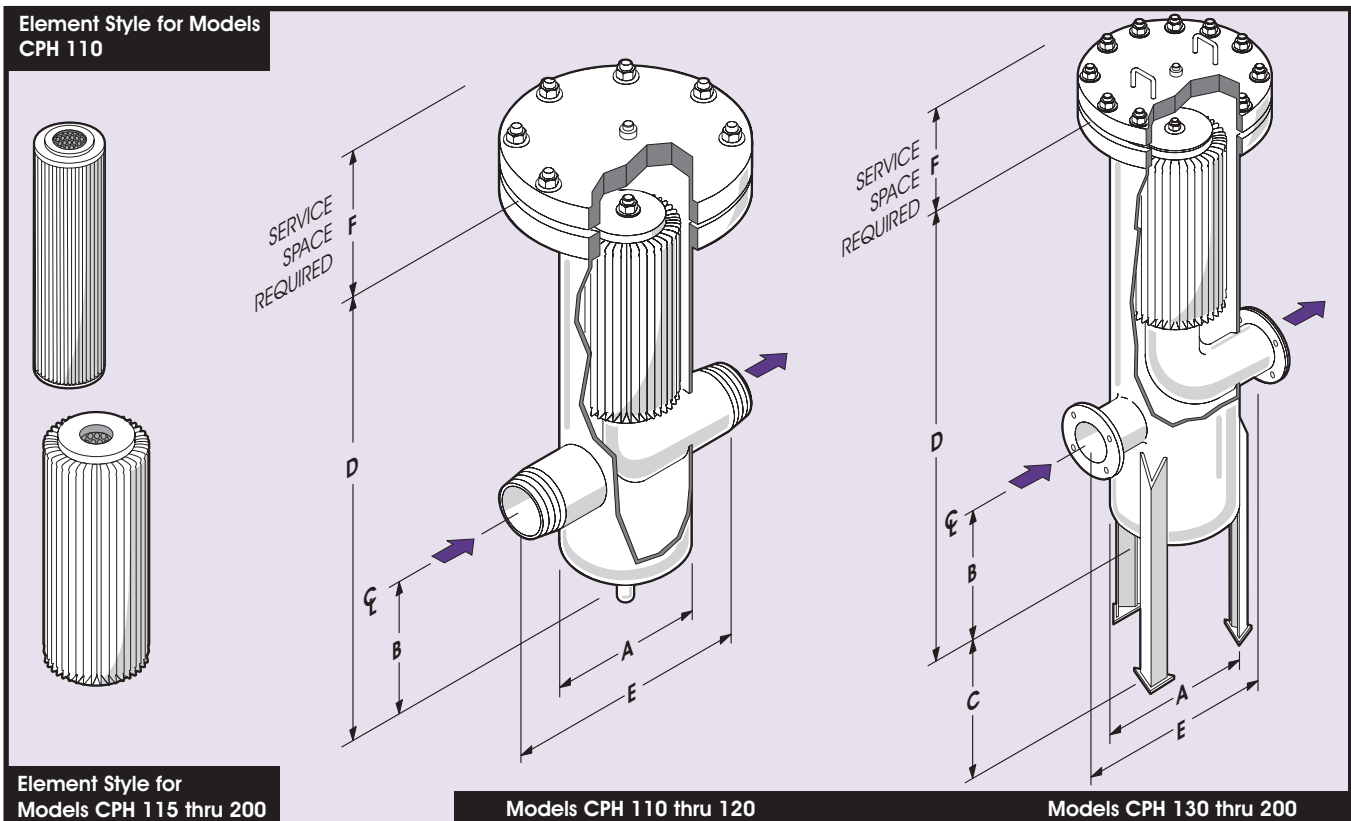

CPH Series Flow Capacities¹

Capacity (SCFM) vs. Differential Pressure (psi)
At 60° F–Specific Gravity 1.0 (Air)²

INLET PRESS	CPH MODEL	psi Δ p				
		0.25	0.5	1.0	2.0	3.0
200 psig	110-005 MT	52	74	104	146	178
	110-007 MT	88	124	175	246	305
	110-010 MT	152	215	300	420	520
	120-015 MT	360	510	710	1000	1220
	130-020 FL	590	840	1180	1660	2020
	140-030 FL	1400	1950	2750	3850	4700
	150-040 FL	2350	3350	4700	6600	8100
	160-060 FL	5200	7300	10200	14500	17700
	180-080 FL	8900	12600	17800	25000	30500
	190-100 FL	14500	20500	28800	40800	49000
	200-120 FL	21500	30000	42000	60000	72000

INLET PRESS	CPH MODEL	psi Δ p				
		0.25	0.5	1.0	2.0	3.0
250 psig	110-005 MT	58	82	115	162	200
	110-007 MT	98	138	195	276	335
	110-010 MT	168	238	332	470	570
	120-015 MT	400	560	800	1120	1380
	130-020 FL	660	930	1320	1850	2250
	140-030 FL	1530	2170	3050	4300	5200
	150-040 FL	2600	3700	5200	7300	8900
	160-060 FL	5700	8000	11200	15800	19200
	180-080 FL	9900	14000	19500	27500	34000
	190-100 FL	16000	22800	32000	45000	54800
	200-120 FL	23800	33500	47000	66000	80000

1. Values are based on actual test data or empirical calculations.

2. To determine proper filter sizing for gases other than air, multiply pressure drop by the correction factor for the appropriate gas from chart on back cover. For temperatures greater than 60° F, multiply pressure drop by the absolute temperature factor:

$$\frac{460 + (^{\circ}\text{F})}{520}$$

3. For inlet pressures less than 200 PSIG, refer to previous flow charts

(Continued from page 1)

For model CP 120 a less expensive V-band closure is available in place of the standard swing bolt style. The V-band makes the filters lighter in weight and quicker to service. The optional V-band is not suitable for applications requiring vessels built to ASME code requirements. All models provide a large volume sump area for collection of contaminants below the filter element.

Standard filter housing may also be modified and customized to meet unique or special applications needs. Typical design modifications include:

- Special leg lengths and skirts
- End connection types
- Inlet/Outlet orientations
- Horizontal vessel designs
- Cover lifting devices
- Special controls and accessories.

Filter Materials and Ratings

- Housings – Carbon Steel Standard
Available: 304SS, 316SS, 316LSS, Hastelloy

- Pressure/Temperature Ratings

CP Series

- CP 110: 150 psig at 100° F max.
- CP 115 & larger, threaded connections: 180 psig at 650° F max.
- CP 115 & larger, flanged connections: 180 psig at 466° F max.

CPH Series

All models: 285 psig at 100° F max.

CPHH Series

All models: 740 psig at 100° F max.

- Closure Gasket
CP Series: NEOPRENE, 300° F max.
CPH Series: spiral wound, 650° F max.
CPHH Series: spiral wound, 650° F max.
- Standard Element - "K5"

CP Series

CP 110: Polyester media, wool gaskets; 10 micron nominal retention, 200° F max.; cleanable.
CP 115 & larger: Polyester media, wool gaskets; 10 micron nominal retention, 200° F max.; cleanable and recoverable.

CPH Series

CP 110: Polyester media, wool gaskets; 10 micron nominal retention, 200° F max.; cleanable.
CP 120 & larger: Polyester media, wool gaskets; 10 micron nominal retention, 200° F max.; cleanable and recoverable.

CPHH Series

CP 110: Polyester media, wool gaskets; 10 micron nominal retention, 200° F max.; cleanable.
CP 120 & larger: Polyester media, wool gaskets; 10 micron nominal retention, 200° F max.; cleanable and recoverable.

CPHH Series Specifications

Model No.	Conn.		Dimensions-Inches ¹					Housing Gasket Part No.	Element			Approx. Weight Lbs.
	Size	Style	A	B	D	E	F		Part No.	No Req'd.	Total filter Area Sq. Ft.	
CPHH 110-005 MT	1/2	MPT	4 1/2	4	15 3/4	10	10	6034PSO	10824K5	1	1.8	75
CPHH 110-007 MT	3/4	MPT	4 1/2	4	15 3/4	10	10	6034PSO	10824K5	1	1.8	75
CPHH 110-010 MT	1	MPT	4 1/2	4	15 3/4	10	10	6034PSO	10824K5	1	1.8	75
CPHH 120-015 MT	1 1/2	MPT	6 5/8	5 3/4	23 1/4	13 1/2	12	6035PSO	19584K5 ²	1	3.9	130
CPHH 130-020 FL	2	FLG	8 5/8	7 1/4	23 1/4	18	12	6036PSO	19585K5 ²	1	6.6	270
CPHH 140-030 FL	3	FLG	8 5/8	7 3/4	30 1/2	18	17	6036PSO	19586K5 ²	1	9.8	290
CPHH 150-040 FL	4	FLG	10 3/4	9 1/4	37 3/4	20	21	6037PSO	19587K5 ²	1	15.4	475
CPHH 160-060 FL	6	FLG	12 3/4	11 1/2	47	22 3/4	26	6038PSO	19794K5 ²	2	33.5	800
CPHH 180-080 FL	8	FLG	16	13	77	26	26	6039PSO	19571K5 ²	2	62.6	1490
CPHH 190-100 FL	10	FLG	20	15 1/2	80	32	26	6040PSO	19758K5	2	95.0	2250
CPHH 200-120 FL	12	FLG	24	17 1/2	86	36	27	6041PSO	19572K5	2	136.0	3405

1. All dimensions are approximate. 2. See optional elements, pg. 8.

- Standard filters are supplied with 10 micron polyester filter medium. Contact your Conster representative for other available materials.
- Models CPHH 120 thru 200 have 1/4" NPT plugged gauge connections.
- Models CPHH 110 thru 150 have 1/2" NPT plugged drain and vent connections.
- Models CPHH 160 thru 200 have 1" NPT plugged drain and vent connections.
- Models CPHH 130 thru 190 have three (3) leg supports with length of 18" from bottom of vessel to grade.
- Model CPHH 200 has four (4) leg supports with length of 18" from bottom of vessel to grade.
- Models CPHH 120 thru 140 have two (2) handles for closure removal.
- Models CPHH 150 thru 200 have a swing away davit device and one (1) handle.
- Flanged models have 300# ANSI, R.F. flanges.
- Models CPHH 110 thru 120 available with flanges.
- CPHH Series standard gasket material is a CG style spiral wound, with 304 Stainless Steel compression ring and graphite filler.

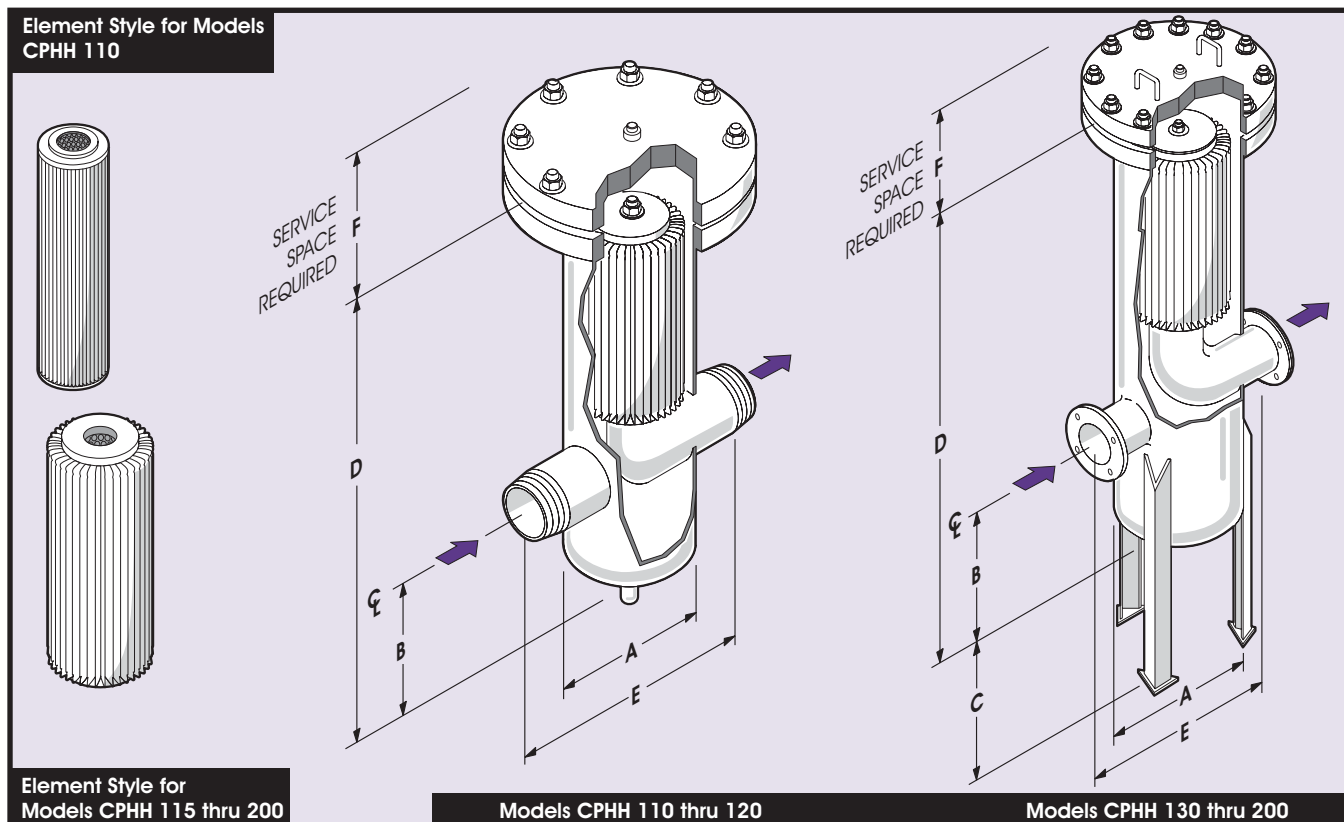

CPHH Flow Rate Capability Charts¹

Capacity (SCFM) vs. Differential Pressure (psi)
At 60° F–Specific Gravity 1.0 (Air)²

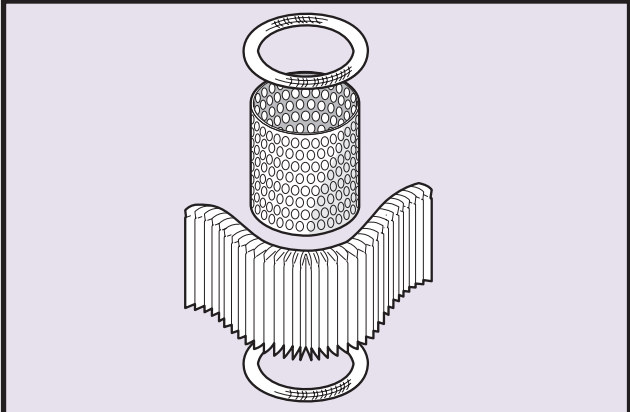
Inlet Press	CPHH Model	psi Δ p						Inlet Press	CPHH Model	psi Δ p					
		0.5	1.0	2.0	3.0	4.0	5.0			0.5	1.0	2.0	3.0	4.0	5.0
300 psig	110-005 MT	90	128	180	220	255	285	600 psig	110-005 MT	123	175	250	305	350	390
	110-007 MT	152	218	305	380	430	480		110-007 MT	205	290	410	500	580	650
	110-010 MT	265	375	530	650	750	840		110-010 MT	355	500	710	860	1000	1110
	120-015 MT	620	880	1240	1520	1750	1950		120-015 MT	840	1180	1680	2050	2380	2650
	130-020 MT	1010	1450	2050	2500	2900	3200		130-020 MT	1400	2000	2800	3430	3980	4400
	140-030 MT	2380	3350	4780	5800	6700	7500		140-030 MT	3250	4600	6460	7900	9200	10200
	150-040 MT	3640	5150	7300	8900	10300	11400		150-040 MT	5060	7100	10200	12400	13400	16000
	160-060 MT	7980	11200	15900	19500	22500	25000		160-060 MT	10900	15500	22000	27000	31000	34600
	180-080 MT	14500	21000	29300	36000	41800	46200		180-080 MT	20200	28700	40800	50000	58000	64200
	190-100 MT	22000	31000	44000	54000	62000	69000		190-100 MT	31000	43800	62000	76000	88000	98000
200-120 MT	32000	46000	64000	78000	91000	101000	200-120 MT	45000	64000	90000	110000	127000	142000		
400 psig	110-005 MT	103	145	205	250	290	325	720 psig	110-005 MT	138	192	272	335	385	430
	110-007 MT	175	250	350	430	500	560		110-007 MT	230	325	460	560	660	730
	110-010 MT	295	420	590	720	840	950		110-010 MT	400	570	810	1000	1150	1280
	120-015 MT	700	990	1400	1720	2000	2200		120-015 MT	940	1320	1880	2300	2650	2950
	130-020 MT	1150	1620	2300	2800	3270	3650		130-020 MT	1550	2200	3130	3850	4450	4900
	140-030 MT	2700	3800	5400	6600	7600	8500		140-030 MT	3640	5150	7300	8900	10300	11400
	150-040 MT	4100	5830	8270	10100	11700	13000		150-040 MT	5500	7760	11000	13500	15600	17400
	160-060 MT	8980	12700	18000	22000	25500	28300		160-060 MT	12200	17200	24500	29800	34200	38300
	180-080 MT	17000	24000	33800	41600	48000	53000		180-080 MT	22500	32000	45700	55800	64000	71800
	190-100 MT	25200	36000	50500	62000	72000	80000		190-100 MT	33800	48000	67500	82000	95000	106000
200-120 MT	37000	52000	74000	90000	105000	116000	200-120 MT	49000	70000	100000	120000	140000	155000		
500 psig	110-005 MT	113	160	228	280	320	360								
	110-007 MT	188	270	385	470	540	600								
	110-010 MT	325	460	660	800	930	1030								
	120-015 MT	770	1100	1550	1900	2200	2450								
	130-020 MT	1280	1820	2580	3200	3680	4100								
	140-030 MT	3000	4220	6000	7400	8500	9500								
	150-040 MT	4600	6500	9100	11200	12900	14400								
	160-060 MT	10000	14200	20200	24700	28500	32000								
	180-080 MT	19000	27000	38000	46200	54000	60000								
	190-100 MT	28000	39500	56000	68000	79000	88000								
200-120 MT	41000	58000	82000	100000	115000	130000									

1. Values are based on actual test data or empirical calculations.
2. To determine proper filter sizing for gases other than air, multiply pressure drop by the correction factor for the appropriate gas from chart on back cover. For temperatures greater than 60° F, multiply pressure drop by the absolute temperature factor: $\frac{460 + (°F)}{520}$



Consler Recovery Service
 Consler Filtration Products provides a factory Recovery Service that will extend the life of a filter element, saving the user up to 65% of the cost of a new element.

Most standard vessels are equipped with a cleanable sewn-end element. After several cleanings in the field, used elements can be returned to the factory for recovery. The element frame is stripped of its filter medium, cleaned, inspected for mechanical integrity, and repaired if necessary. The element frame is then covered with new filter media identical to the original, and promptly returned to the user. It is essentially the same as a new filter element. For details, contact your Consler representative or Consler Filtration Products.

△ P Correction Factors

(Specific Gravity Relative to Air)

Gas	Chem. Formula	Molecular Weight	△ P Correction Factor
Acetylene	C ₂ H ₂	26.00	0.897
Air	---	28.96	1.000
Ammonia	NH ₃	17.03	0.587
Argon	A	39.94	1.377
Bromine	Br ₂	159.83	5.519
Butane	C ₄ H ₁₀	58.12	2.007
Carbon Dioxide	CO ₂	44.01	1.520
Chlorine	Cl ₂	70.91	2.446
Ethane	C ₂ H ₆	30.07	1.039
Ethylene	C ₂ H ₄	28.05	0.967
Fluorine	F ₂	38.00	1.312
Helium	He	4.00	0.138
Hydrogen	H ₂	2.02	0.069
Methane	CH ₄	16.04	0.554
Natural Gas	---	---	0.610
Nitrogen	N ₂	28.02	0.967
Oxygen	O ₂	32.00	1.103
Propane	C ₃ H ₈	44.10	1.523
Propylene	C ₃ H ₆	42.08	1.453
Sulfur Dioxide	SO ₂	64.07	2.208
Vinyl Chloride	CH ₂ CHCl	62.50	2.158

(Reference: Mechanical Engineers' Handbook by L.S. Marks, copyright May 1954; McGraw-Hill Book Co., Inc.)
For correction factors for gases other than those listed above, contact Consler.

Optional Molded End Elements

Less expensive PVC molded-end style elements may be substituted for the standard sewn-end elements for some applications. Principal use would be for air, nitrogen, carbon dioxide or natural gas service, at temperatures from -20° F to 200° F. Molded elements should not be used in oxygen or hazardous applications, and they are not recoverable.

Graver Technologies also manufactures these types of Consler brand filtration products:

- Air Intake Filters
- Air Intake Filter/Silencers
- Air/Gas Pressure Filters
- Vacuum Filters
- Liquid Filters/Strainers
- Smoke/Oil Mist Eliminators
- Filter Separators (Pressure Service)
- Special and Custom-Designed Filters and Filter Elements
- Lube Oil Filters and Filter Elements

Graver Technologies has representatives in major cities of the United States, Mexico and Canada. Representatives are also located in many countries around the world.

Graver's manufacturing plant is located in Honeoye Falls, NY. Consler is a registered trade mark of Graver Technologies.

For more detailed information about Consler brand filters, contact your Consler representative or Graver Technologies. Graver has a policy of continued product improvement and reserves the right to change specifications without notice.

Visit our web site at www.gravertech.com

